

ESEA Alert

June 14, 2006

California Teachers Association- Negotiations and Organizational Development Department

ESEA Reauthorization Debate Heats Up *2006 election results will undoubtedly shape the next federal law*

On May 18, 2006, the first in a series of hearings was held by members of the U.S. House Education & the Workforce Committee as they examine the implementation and impact of 2002's No Child Left Behind law.

The Committee's Chair, Rep. Howard "Buck" McKeon (R-CA), said the series of hearings would continue for months and lay the groundwork for the congressional reauthorization effort. Although the timetable is uncertain, **the next ESEA reauthorization would certainly take place after this November's mid-term elections** and could possibly extend beyond the 2008 presidential election, as well.

Despite numerous rule changes, lawsuits, public protests and a state by state rebellion against NCLB's one-size-fits-all approach, U.S. House leaders of both parties expressed support for NCLB.

Rep. McKeon, whose House district encompasses the Santa Clarita & Antelope Valleys, as well as all of Inyo and Mono counties, noted that, **"after decades of failed reform efforts, coupled with hundred of billions of taxpayer dollars spent with little of no success in closing the achievement gap, the impact of No Child Left Behind has been dramatic-- and a positive step forward for students, teachers, parents, and taxpayers."** McKeon said he's willing to listen to the complaints about various aspects of the law, but he's more interested in how to solve any problems.

To that end, the National Education Association has taken an active role in proposing rule changes and legislative amendments to address many of the glaring weaknesses of the law. Following this July's NEA Representative Assembly, there will be a major effort to get Congress to listen to the nation's working educators. The goal is to improve ESEA in the next reauthorization by substantially correcting the flaws of NCLB, retaining the beneficial elements of the original ESEA, and adding positive new provisions.

This fall's political outcomes will have a major impact on the next version of ESEA. As always, our teachers must continue to take an active role in the political process to insure that there is a climate in Washington that supports fundamental change and full funding under the law.

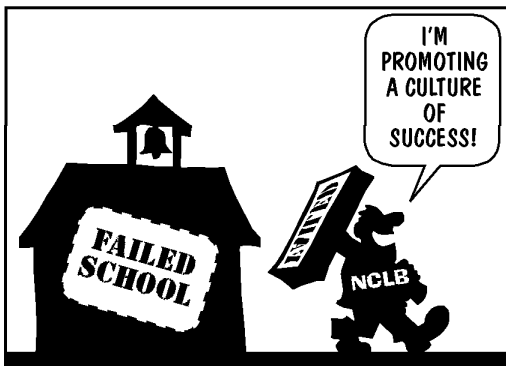
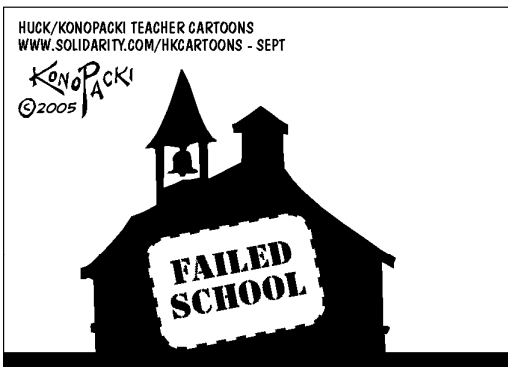

Courts Rule Against NEA, School Districts in Lawsuit

On April 2005, a diverse network of school districts, the National Education Association (NEA) and several state education associations filed the first-ever national lawsuit to force the Bush Administration to pay the costs of its own rules and regulations under NCLB.

In November, U.S. District Judge Bernard Friedman granted the federal government's motion to dismiss NEA's complaint. That decision was appealed in March 2006.

NEA's appeal is being supported by seven states (CT, DE, IL, ME, NM, OK, WI) and Washington D.C; the governor of Pennsylvania; as well as the American Association of School Administrators and a variety of state and local elected officials from California.

California Teachers Association

www.cta.org

For More Information:

NEA has a link, by local zip code, to your own D.C. legislator. Teachers can compose and send personal communications to their representatives about the importance of fixing ESEA in the next reauthorization.

Go to the website:

www.nea.org/eSEA/index.html

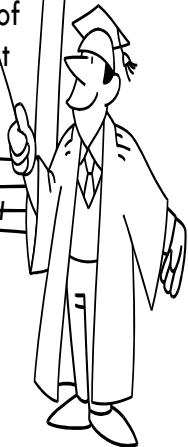

The Road Ahead...

According to *Education Week*, April 5, 2006

A recent report concludes that NCLB has not superseded teachers' contracts and changes in working conditions mandated by the NCLB's Program Improvement process must be bargained with teachers.

However, this report goes on call for teachers to back down on seniority privileges, pensions and performance pay, among other issues.

The report, "A Better Bargain: Overhauling Teacher Collective Bargaining for the 21st Century," calls for pay systems to be based on the scarcity and value of a teachers' skills, the difficulty of their assignment...and the caliber of their work.

It also calls for explicit language maximizing the "operational flexibility" of administrators and "consultation-only" rights for teachers.

What is the Current Situation Regarding NCLB?

According to the NEA's Comprehensive Strategies for ESEA Authorization Report

(published on May 2, 2006 for presentation to RA delegates in July)

- ◆ While polling demonstrates that the majority of the public still support core elements of NCLB, the more people know about the law, the less they support it. There is significant public support for changes to the law consistent with NEA's policy proposals.
- ◆ Without significant public and member pressure to support alternatives, it will be difficult to overcome current congressional support for NCLB.
- ◆ Budgets are being cut at the federal and state levels, and there are competing budget interests— the war in Iraq, Medicaid, tax cuts and others. NCLB funding was actually cut by \$1 billion for fiscal year 2006.
- ◆ The timing of the final passage of an ESEA reauthorization bill is unclear and may require a rapid reassessment of strategy.
- ◆ State legislators and other state and local officials are becoming more willing to support major changes to NCLB.
- ◆ Within Congress there is growing support among both Republicans and Democrats for making significant changes to NCLB.
- ◆ A growing alliance of organizations are willing to work together to change specific provisions of NCLB.
- ◆ As NCLB deadlines quickly approach, more and more rank and file members are aware of and anxious about NCLB.
- ◆ Increasing numbers of schools and districts failing to meet Adequate Yearly Progress (AYP) targets will increase member, parent, and public pressure for changes to the law.
- ◆ NEA's new focused ESEA reauthorization priorities can be used to energize and mobilize our members and local affiliates. These priorities include:
 - ◆ **Accountability That Rewards Success and Supports Educators to Help Students Learn**
 - ◆ **Smaller Class Sizes to Improve Student Achievement**
 - ◆ **Quality Educators in Every Classroom and School**
 - ◆ **Students and Schools Supported by Active and Engaged Parents, Families and Communities**
 - ◆ **Resources to Ensure a Great Public School for Every Child**

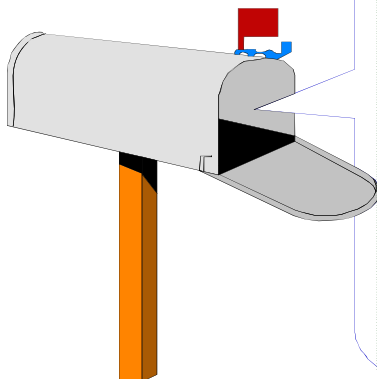

Look for CTA's new **ESEA Postcard Campaign** focused on the elimination of NCLB.

Begun in March 2006 by the Tulare-Kings Service Center, the postcards can be signed and mailed by both educators and community members.

This organizing campaign can help teachers connect with parents, businesses & other civic organizations.

Coming soon to your local area.